



Features

- 15" XGA color TFT LCD with resolution up to 1024 x 768
- 550 nits brightness
- Standard RGB(VGA) interface for the display
- Stainless steel chassis with IP65-compliant aluminum front panel
- OSD key on back cover
- Supports panel mount

Introduction

The FPD-150T is a 15 inch XGA color TFT LCD flat panel monitor with resistive type touch screen. It is specifically designed for industrial applications. Its many industrial-grade features include IP65-compliant, aluminum front panel protection, steel chassis and panel mount and is especially suitable for applying with industrial PC.

Ordering Information

- ▶ **FPD-150T**
15" XGA TFT LCD Industrial Flat Panel Display with Touch Screen.

Specifications

System

- **Input Signal** RGB
- **Control** OSD (on screen display) control pads on the rear cover
- **OS Support** Windows 98/2000/XP

Mechanical

- **Construction** Stainless steel chassis & aluminum alloy front panel
- **Front Panel** IP65 compliant
- **Mounting** Panel Mounting
- **Dimension** 420mm(W) x 320mm(H) x 56.5mm(D)
(16.5" x 12.6" x 2.22")
- **Gross Weight** 7.95KG

Power Adapter

- **External Power** AC/DC power adapter (optional)

Environmental Specifications

- **Operating Temperature** 0 ~ 50°C
- **Storage Temperature** -10 ~ 60°C
- **Operating Humidity** 20% ~ 80%RH, Non-condensing
- **Vibration** 10 ~ 200HZ 1.5G 30mins each X,Y,Z

LCD Panel

- **Display Size** 15"
- **Display Type** XGA TFT LCD
- **Max. Colors** 262K
- **Pixel Pitch** 0.297 x 0.297
- **Resolution** 1024 x 768
- **Luminance** 550cd/m² (Typ.)
- **Contrast Ratio** 400:1 (Typ.)
- **Response Time** 16ms (Typ.)
- **Viewing Angle** 120°(H), 100°(V)
- **Lamp Life Time** 50,000 hrs (Typ.)

Touch Screen Panel

- **Type** 8-wire, analog resistive
- **Light Transmission** >80%
- **Controller** USB 1.1 interface
- **Durability** 10 millions touches
- **OS Support** Windows 98/2000/XP

Side View

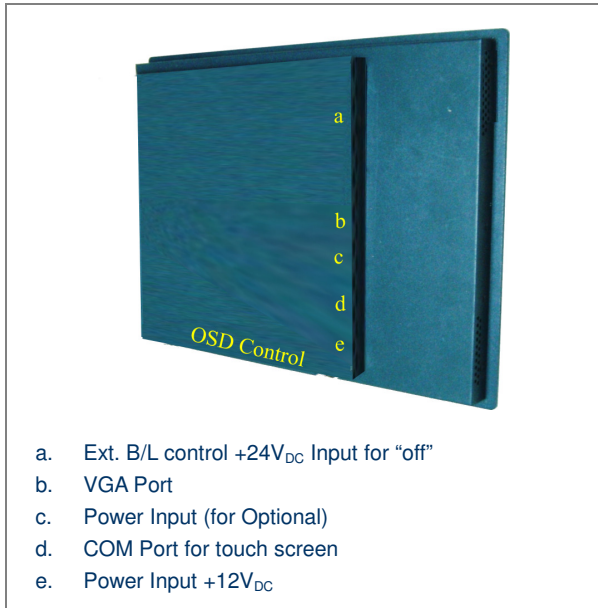

Panel Mounting

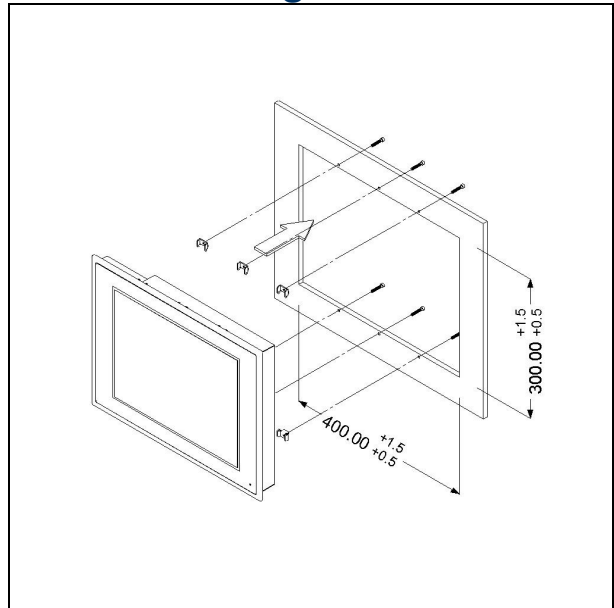

Dimensions

